

J.L. WINGERT CO.

P.O. Box 6207 • Garden Grove, CA 92846-6207 / 11800 Monarch Street • Garden Grove, CA 92841-2113
 Phone (714) 379-5519 • Fax (714) 379-5549 ■ Email: customerservice@jwingert.com
 Northern California Region • Phone (510) 487-5310 ■ Southwest Region • Phone (602) 470-1015
 www.jlwingert.com

MANUFACTURING: Mixers, Bypass Feeders, Filter Feeders, Bromine Feeders, Sample Coolers, Sludge Traps, Separators, Separator Systems, Tank Stands,
 Tank Package Systems, Glycol Feed Systems, Coupon Racks, Control Stations, NEMA Enclosures, Custom Packaged Systems and Specialty Welding

Specification Sheet #012003 Rev. "C" (6/99)

MODEL F-M-TE-[H/PRP/A] / F-M2-TE-[H/PRP/A]

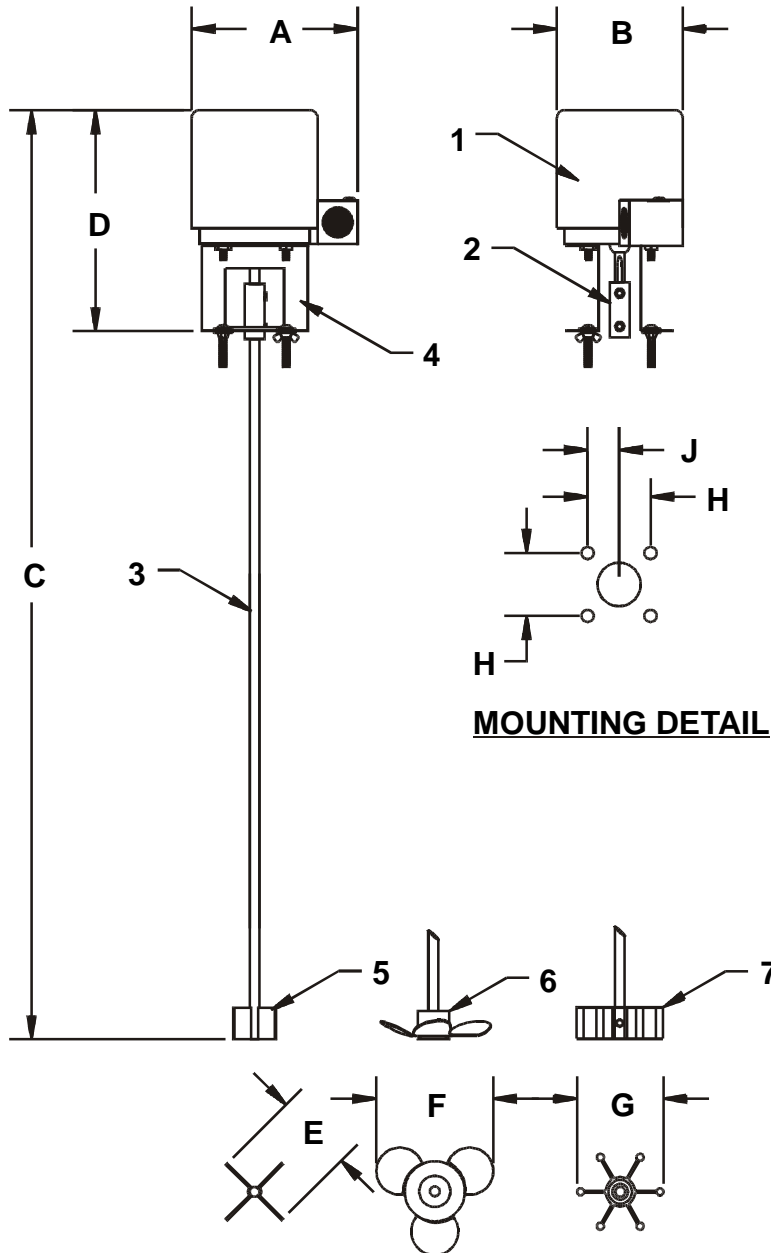

SPECIFICATIONS:

KEY	DESCRIPTION
1	MOTOR: 1/20 HP, TEFC (F-M-TE-[])
	MOTOR: 1/20 HP, TEFC (F-M2-TE-[])
2	COUPLING: 5/16" x 5/16" bored brass coupling with stainless set screws
3	SHAFT: 5/16" D x 28" L, 316 stainless steel shaft (for neoprene impeller, SS impeller & propeller)
4	MOUNT: Flange brackets are stamped gauge steel, hardware is plated steel
5	[H] SS IMPELLER: 316 stainless steel fabricated to shaft
6	[PRP] PROPELLER: 316 stainless steel propeller with stainless steel set screws
7	[A] NEOPRENE IMPELLER: Small neoprene impellers with brass/copper hub

* NOTE: Shaft and [H] style stainless steel impellers are prefabricated at the factory (not sold individually)

DIMENSIONS, WEIGHT & CUBE:

KEY	F-M-TE-[]	F-M2-TE-[]
A	5 3/8"	5 3/8"
B	4" diameter	4" diameter
C	34 7/8"	34 7/8"
D	7"	7"
E	1 3/4"	1 3/4"
F	4" diameter	4" diameter
G	1 3/4"	1 3/4"
H	2"	2"
J	1"	1"
Weight	9 lbs. approx.	9 lbs. approx.
Cube	5" X 5" X 36"	5" X 5" X 36"

MOTOR DATA:	F-M-TE-[]	F-M2-TE-[]
Voltage	115	230
Phase / Hertz	1 / 60	1 / 60
Full Load Amps	1.5	.75
Service Factor	1.0	1.0
Insulation Class	A	A

Note: All dimensions are +/- 1/8". All weights are approximate. All dimensions are subject to change without notice.